

TO-220-2L Plastic-Encapsulate Diode

MUR20H60L HYPERFAST RECTIFIER, FRED

MAIN CHARACTERISTICS

I_O	20A
V_{RRM}	600V
T_{rr}	24ns
T_j	175°C
V_{F(typ)}	1.1V(@T_j=150°C)

FEATURES

- Ultrafast Recovery Times and Low Recovery Loss
- Low Forward Voltage
- Low Reverse Leakage Current

APPLICATIONS

Specifically designed to improve efficiency of PFC and output rectification stages of EV / HEV battery charging stations, booster stage of solar inverters and UPS applications, these devices are perfectly matched to operate with MOSFETs or high speed IGBTs.

MARKING

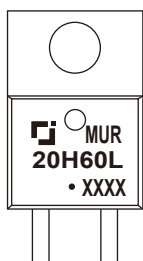

MUR20H60L = Device code
 Solid dot = Green molding compound device
 if none, the normal device
 XXXX = Code

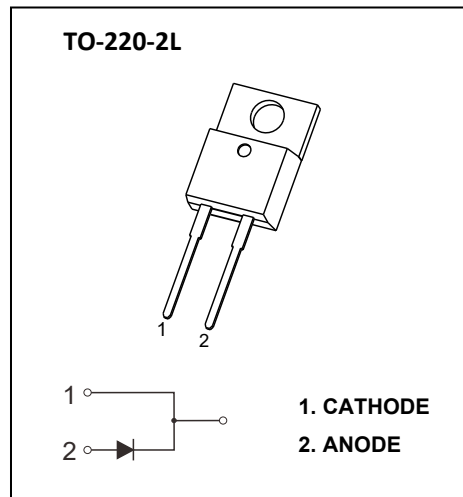

MAXIMUM RATINGS (T_c=25°C unless otherwise noted)

Symbol	Parameter	MUR20H60L	Unit
V_{RRM}	Peak Repetitive Reverse Voltage	600	V
V_R	DC Blocking Voltage		
I_{F(AV)}	Average Forward Current(T _C =119°C)	20	A
I_{F(RMS)}	RMS Forward Current(T _C =119°C)	28	A
I_{FSM}	Non-Repetitive Surge Forward Current (8.3ms)	300	A
P_D	Power dissipation	86	W
R_{θJC}	Thermal Resistance From Junction to Case	1.74	°C/W
T_j	Operating Junction Temperature Range	-55 ~ +175	°C
T_{stg}	Storage Temperature Range	-55 ~ +175	°C

Typical Characteristics

ELECTRICAL CHARACTERISTICS ($T_c=25^\circ\text{C}$ unless otherwise specified)

Symbol	Parameter	Test Conditions	Min.	Typ.	Max.	Unit
$V_{(BR)}$	Reverse Voltage	$I_R=100\mu\text{A}$	600			V
I_R	Reverse Current	$V_R=600\text{V}$	$T_j=25^\circ\text{C}$		10	μA
			$T_j=150^\circ\text{C}$		500	μA
V_F	Forward Voltage	$I_F=20\text{A}$	$T_j=25^\circ\text{C}$	1.41	1.6	V
			$T_j=150^\circ\text{C}$	1.1		V
C_{tot}	Total Capacitance	$V_R=200\text{V}, f=1\text{MHz}$		30		pF
trr	Reverse Recovery time	$I_F=0.5\text{A}, I_R=1\text{A}, I_{rr}=0.25\text{A}$		35		ns
		$I_F=1\text{A}, V_R=30\text{V}, di_F/dt=200\text{A}/\mu\text{s}$		24		ns

ELECTRICAL CHARACTERISTICS ($T_c=25^\circ\text{C}$ unless otherwise specified)

Symbol	Parameter	Test Conditions	Min.	Typ.	Max.	Unit
trr	Reverse Recovery Time	$I_F=20\text{A}, V_R=400\text{V}, di_F/dt=200\text{A}/\mu\text{s}$		72		ns
I_{RRM}	Max. Reverse Recovery Current			4.2		A
Qrr	Reverse Recovery Charge			183		nC
trr	Reverse Recovery Time	$I_F=20\text{A}, V_R=400\text{V}, di_F/dt=200\text{A}/\mu\text{s}, T_j=125^\circ\text{C}$		102		ns
I_{RRM}	Max. Reverse Recovery Current			9		A
Qrr	Reverse Recovery Charge			513		nC
trr	Reverse Recovery Time	$I_F=20\text{A}, V_R=400\text{V}, di_F/dt=600\text{A}/\mu\text{s}, T_j=125^\circ\text{C}$		59		ns
I_{RRM}	Max. Reverse Recovery Current			24		A
Qrr	Reverse Recovery Charge			770		nC

Typical Characteristics

Forward Characteristics

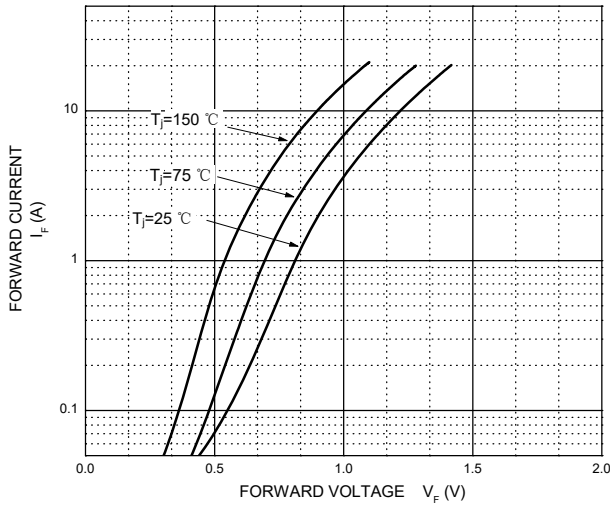

Reverse Characteristics

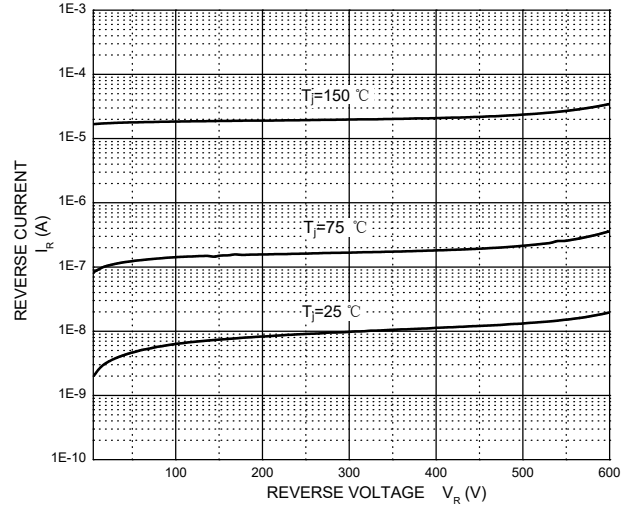

Capacitance Characteristics Per Diode

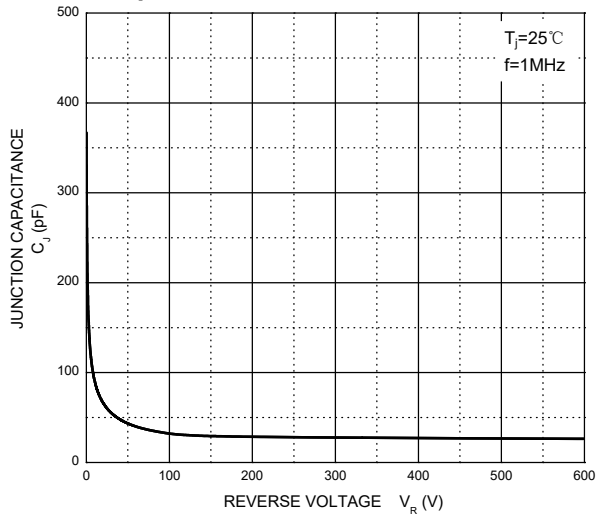

Reverse Recovery Time vs. di_F/dt

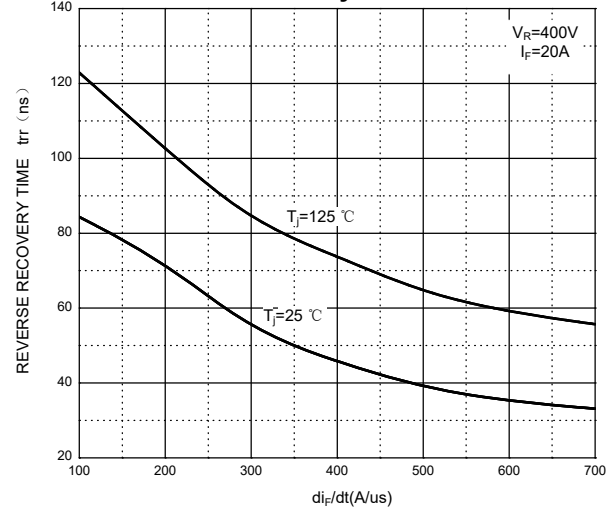

Stored Charge vs. di_F/dt

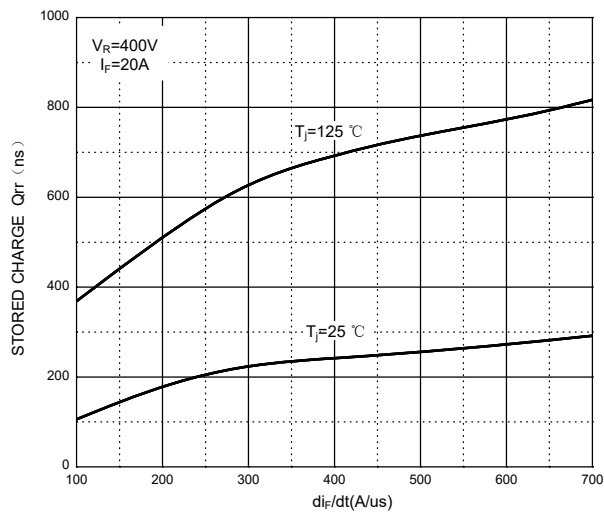

Recovery Current vs. di_F/dt

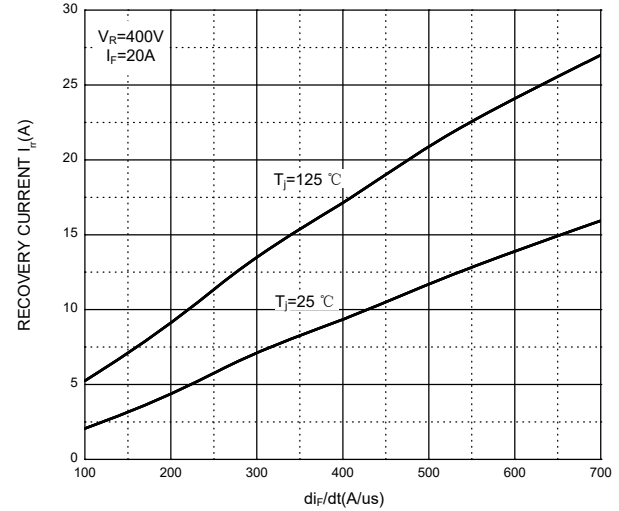

Typical Characteristics

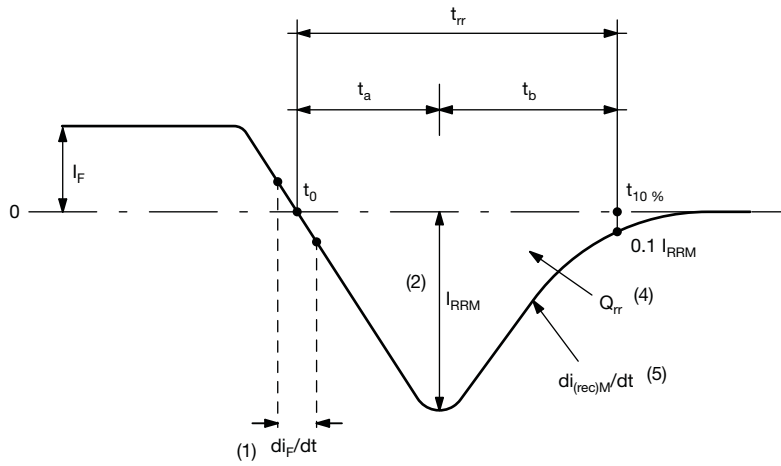

Reverse Recovery Waveform and Definitions

MUR20H60L Transient Thermal Impedance, Junction-Case

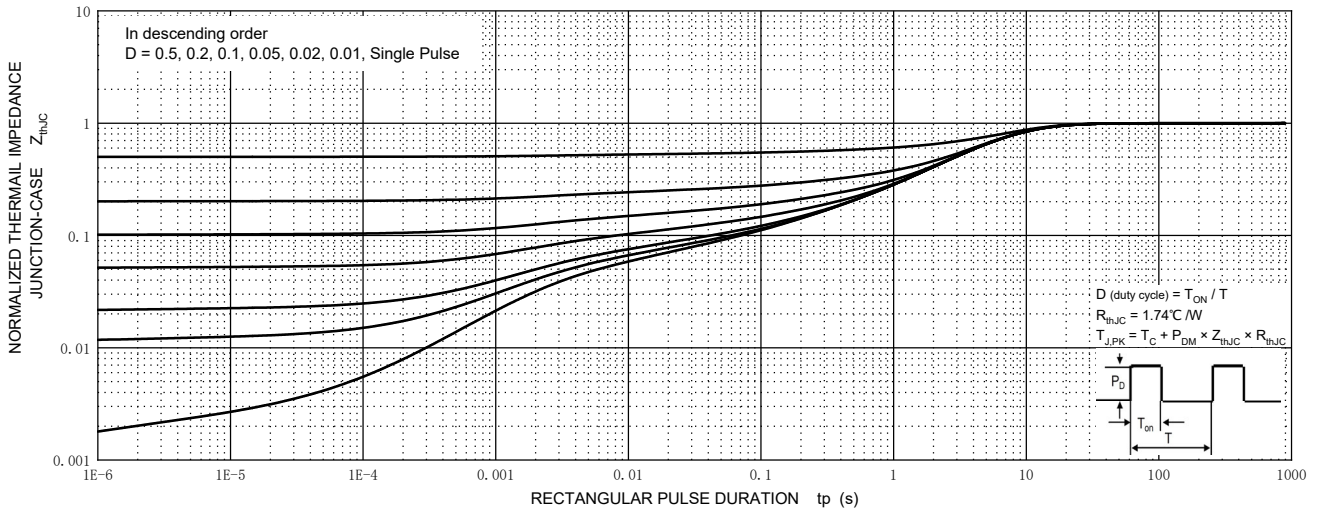

TO-220-2L Package Outline Dimensions

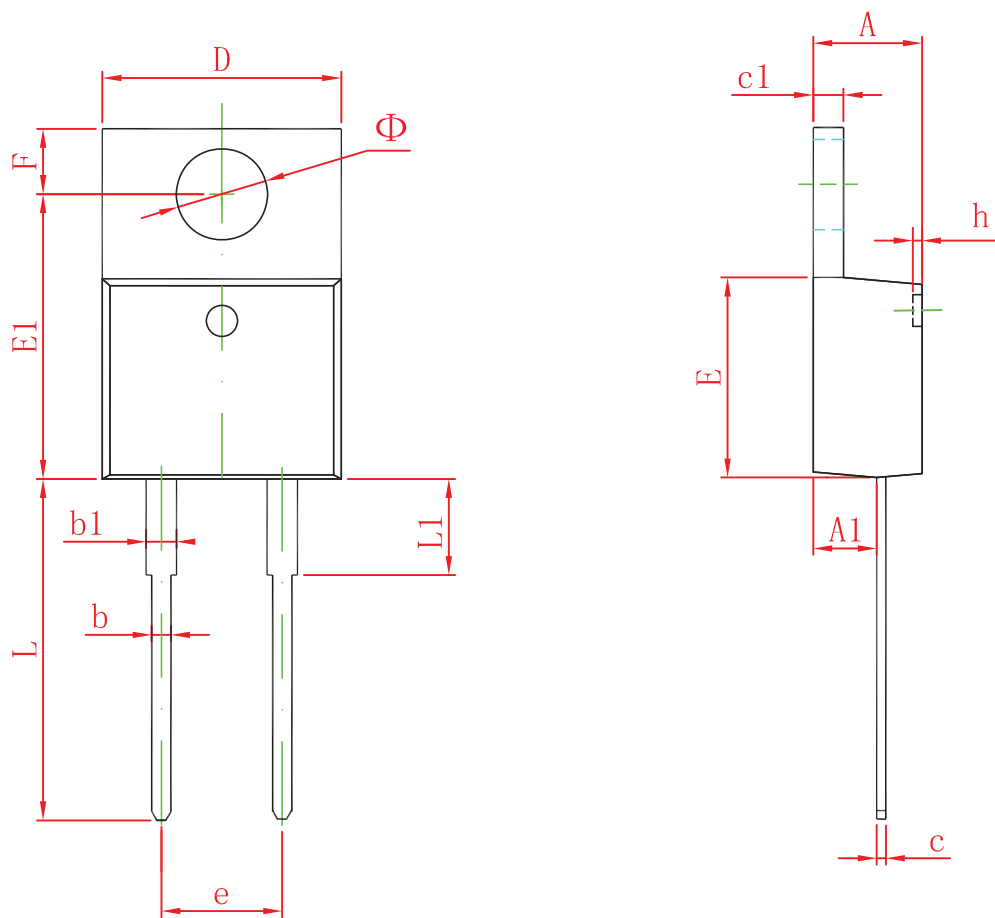

Symbol	Dimensions In Millimeters		Dimensions In Inches	
	Min	Max	Min	Max
A	4.450	4.750	0.175	0.187
A1	2.520	2.820	0.099	0.111
b	0.710	0.910	0.028	0.036
b1	1.170	1.370	0.046	0.054
c	0.300	0.500	0.012	0.020
c1	1.170	1.370	0.046	0.054
D	9.830	10.330	0.387	0.407
E	8.500	8.900	0.335	0.350
E1	12.050	12.650	0.474	0.498
e	5.080 TYP		0.200 TYP	
F	2.540	2.940	0.100	0.116
h	0.100 TYP		0.004 TYP	
L	13.300	13.800	0.523	0.543
L1	3.540	3.940	0.139	0.155
Φ	3.735	3.935	0.147	0.155