



MBR2045CT

Dual High Voltage Schottky Rectifier

●Features:

- Common Cathode Structure
- Low Power Loss and High Efficiency
- Low Forward Voltage Drop
- High Surge Capability

●Application:

- High Frequency Switch
- Free Wheeling, and Polarity Protection Applications

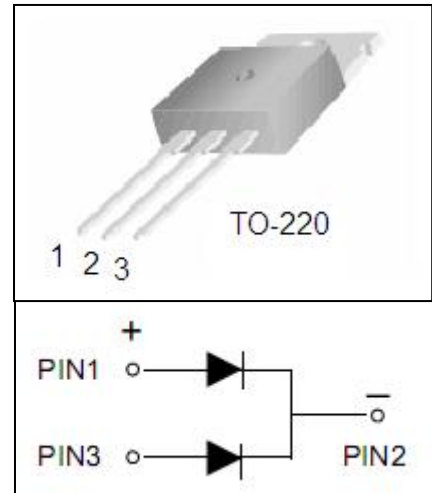

Absolute Maximum Ratings (T_c=25°C unless otherwise noted)

Symbol	Parameter	Value	Unit
V _{RRM}	Maximum Repetitive Reverse Voltage	45	V
V _R	Maximum DC Reverse Voltage	45	V
I _{F(AV)}	Average Rectified Forward Current, T _c =125°C	10(Per Leg) 20(Per Device)	A
I _{FSM}	Peak Forward Surge Current, 8.3ms Half Sine wave	150	A
T _j	Operating Junction Temperature	150	°C
T _{stg}	Storage Temperature Range	-55 to +150	°C

Thermal Characteristics (T_c=25°C unless otherwise noted)

Symbol	Parameter	Max	Unit
R _{θJC}	Thermal Resistance, Junction to Case Per Leg	2.2	°C /W
R _{θJA}	Thermal Resistance, Junction to Ambient Per Leg	92	°C /W

Electrical Characteristics (T_c=25°C unless otherwise noted)

Symbol	Parameter	Test Conditions	Min	Max	Unit
V _{RRM}	Maximum Repetitive Reverse Voltage	I _R =100μA	45		V
I _R	Reverse Current	V _R =45V T _c =25°C V _R =45V T _c =125°C		0.1 50	mA
V _F	Forward Voltage	I _F =10A T _c =25°C I _F =10A T _c =125°C I _F =20A T _c =25°C I _F =20A T _c =125°C		0.55 0.50 0.60 0.55	V



MBR2045CT

Dual High Voltage Schottky Rectifier

Typical Performance Characteristics

Figure 1. Forward Current Characteristics

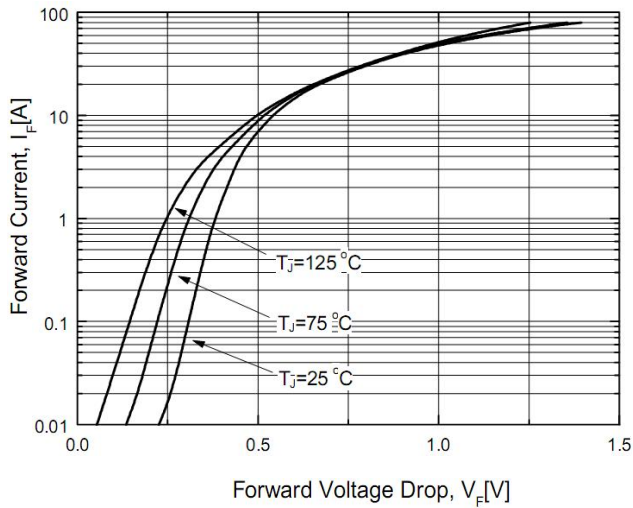

Figure 2. Reverse Leakage Current

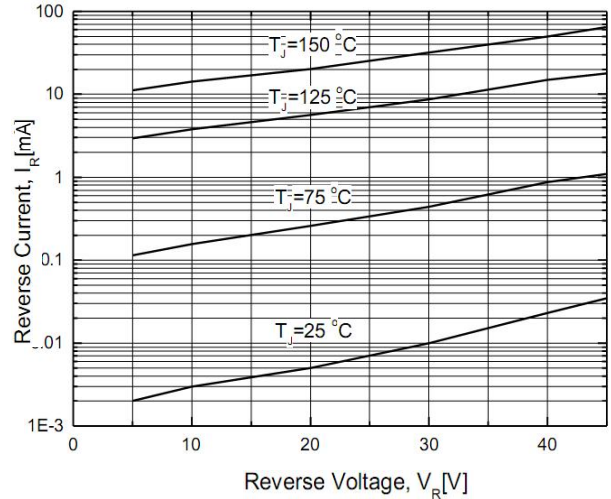

Figure 3. Junction Capacitance

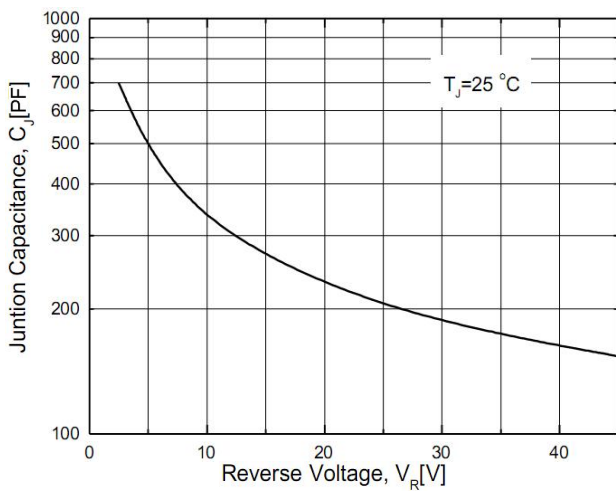
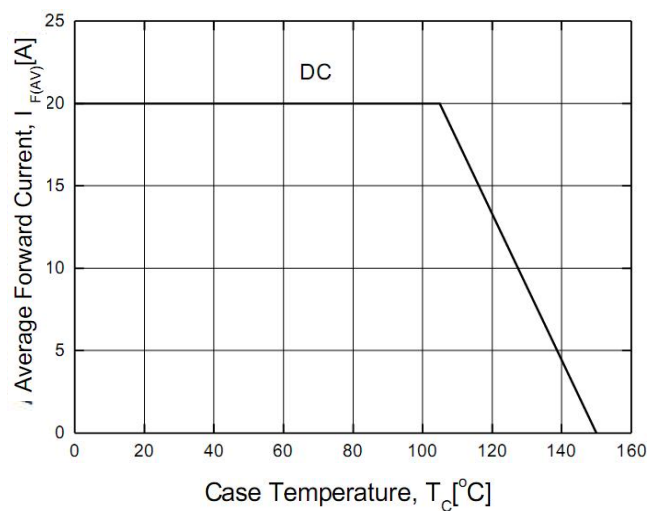

Figure 4. Power Derating





MBR2045CT

Dual High Voltage Schottky Rectifier

UNIT: mm

SYMBOL	min	nom	max	SYMBOL	min	nom	max
A	3.5		4.8	e		2.54	
B			2.4	F	1.1		1.4
B1			1.8	L	12.5		14.5
b	0.6			L1			3.5
$\phi b1$			1.2	L2			6.3
c	0.4			ϕP			
D			16.5	Q	2.5		3.1
D1	5.9		6.9	Q1	2.0		2.8
E			10.7	Z	3.0		

